

# 123 WATT

SUPERIOR DURABILITY. HIGH EFFICIENCY.

## MULTI-CRYSTAL SILICON PHOTOVOLTAIC MODULE WITH 123W MAXIMUM POWER

Sharp's ND-123U1 photovoltaic modules offer industry-leading performance, durability, and reliability for a variety of electrical power requirements. Using breakthrough technology perfected by Sharp's nearly 45 years of research and development, these modules use a textured cell surface to reduce reflection of sunlight, and BSF (Black Surface Field) structure to improve conversion efficiency. An anti-reflective coating provides a uniform blue color and increases the absorption of light in all weather conditions. Common applications include RVs, cabins, solar power stations, pumps, beacons, and lighting equipment. Designed to withstand rigorous weather conditions, a junction box is also provided for easy electrical connections in the field, making Sharp's ND-123U1 modules the perfect combination of advanced technology and reliability.



*Solder-coated grid results in high fill factor performance under low light conditions.*



*Sharp multi-purpose modules offer industry-leading performance for a variety of applications.*



## FEATURES

- High-power module (123W) using 155mm square multi-crystal silicon solar cells with 12.39% module conversion efficiency
- Bypass diode minimizes the power drop caused by shade
- Improved cell conversion efficiency: 14.13%
- Water white, tempered glass, EVA laminate, plus aluminum frame for extended outdoor use
- Junction box for easy electrical connections in the field
- Nominal 12VDC output for battery charging applications
- UL Listings: UL 1703, cUL
- Sharp modules are manufactured in ISO 9001 certified facilities
- 25-year limited warranty on power output (see dealer for details)

### ELECTRICAL CHARACTERISTICS

Cell	Multi-crystal silicon
No. of Cells and Connections	36 in series
Open Circuit Voltage (Voc)	21.3V
Maximum Power Voltage (Vpm)	17.2V
Short Circuit Current (Isc)	8.1A
Maximum Power Current (Ipm)	7.16A
Maximum Power (Pm)*	123W
Minimum Power (Pm)*	110.7W
Encapsulated Solar Cell Efficiency ( $\eta_c$ )	14.13%
Module Efficiency ( $\eta_m$ )	12.39%
PTC Rating (W)**	107.75
Maximum System Voltage	600VDC
Series Fuse Rating	15A
Type of Output Terminal	Junction box

### MECHANICAL CHARACTERISTICS

Dimensions (A x B x C below)	59.02 x 26.06 x 1.81" / 1499 x 662 x 46mm
Weight	30.86lbs / 14.0kg
Packing Configuration	2 pcs per carton
Size of Carton	63.39 x 30.71 x 5.12" / 1610 x 780 x 130mm
Loading Capacity (20 ft container)	196 pcs (98 cartons)
Loading Capacity (40 ft container)	420 pcs (210 cartons)

### ABSOLUTE MAXIMUM RATINGS

Operating Temperature	-40 to 194°F / -40 to +90°C
Storage Temperature	-40 to 194°F / -40 to +90°C
Dielectric Isolation Voltage	2200 VDC max.

### IV CURVES

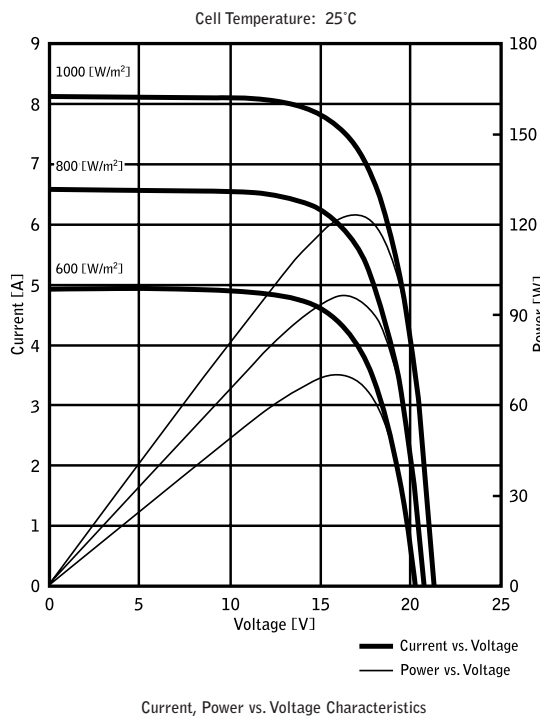

### DIMENSIONS

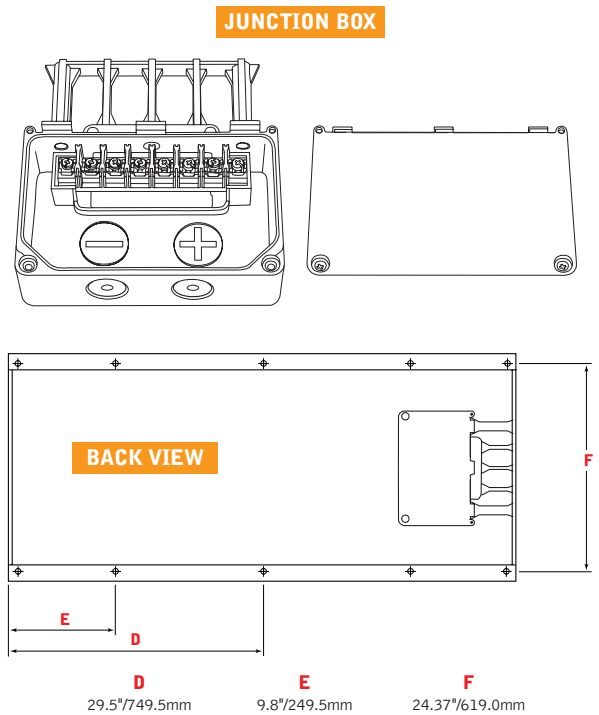

Specifications are subject to change without notice.

\* (STC) Standard Test Conditions: 25°C, 1 kW/m<sup>2</sup>, AM 1.5  
 \*\* (PTC) Pacific Test Conditions: 20°C, 1 kW/m<sup>2</sup>, AM 1.5, 1 m/s wind speed

In the absence of confirmation by product manuals, Sharp takes no responsibility for any defects that may occur in equipment using any Sharp devices. Contact Sharp to obtain the latest product manuals before using any Sharp device.

